

W.I.C.C. Ltd
 119 MULLER RD
 PO Box 252
 WASHINGTON IL 61571
 (309)-444-4125
 FAX (309)-444-3313

CURRENT TRANSFORMER MODEL D

1.50" I.D.

PAGE No

REV 25JUL00

TERMINAL OPTION

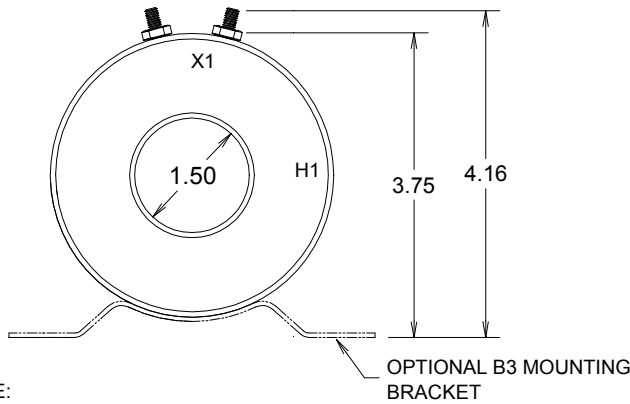
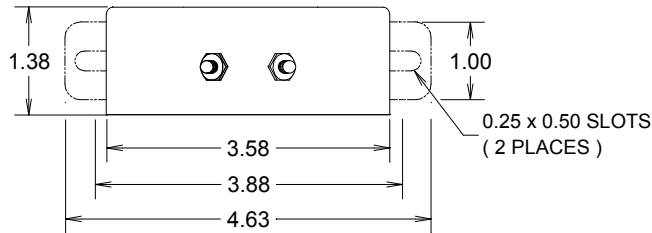

NOTE:
 1) ALL DIMENSIONS IN INCHES
 2) ALL DIMENSIONS REF ONLY

LEAD WIRE OPTION

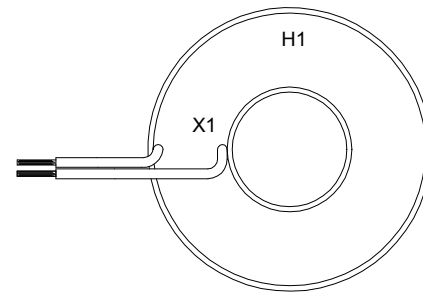
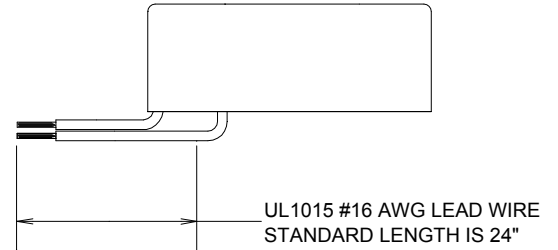

Specifications

- Secondary sources 5 amps AC at rated F.S. primary current
- Nominal operating frequency range is 50-400HZ
- Thermal rating factor is 1.33 @ 30C for all ratios
- Insulation voltage class is 0.6KV BIL 10KV
- For indoor applications only
- Conforms to provisions of IEEE C57.13 and IEC 44-1
- Enclosure is glass-filled nylon, color is black
- Optional bracket is aluminum

Options, contact Factory for information

- UL and Canadian UL Recognized Component. File E100575
- 2.0, 5.0, and 10 VAC output at F.S. primary amperage. Other non-standard ratings also available.
- 1.0, 0.2, and 0.1 A output at F.S. primary amperage. Other non-standard ratings also available
- 8-32 Brass Stud Terminals or #16 AWG UL 1015 Lead Wires
- Custom lead wire lengths and types
- Thermal ratings above 1.33 for selected ratios.
- Available with B3 bracket. See Bracket Data Section for dimensions.
- Center tap and custom multi tap winding arrangements

1.50" I.D.

CURRENT TRANSFORMER
MODEL D

PAGE No

REV 25JUL00

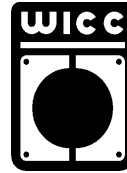

W.I.C.C. Ltd
 119 MULLER RD
 PO Box 252
 WASHINGTON IL 61571
 (309)-444-4125
 FAX (309)-444-3313

TYPICAL EXCITATION CURVE for WICC MODEL D at 60HZ

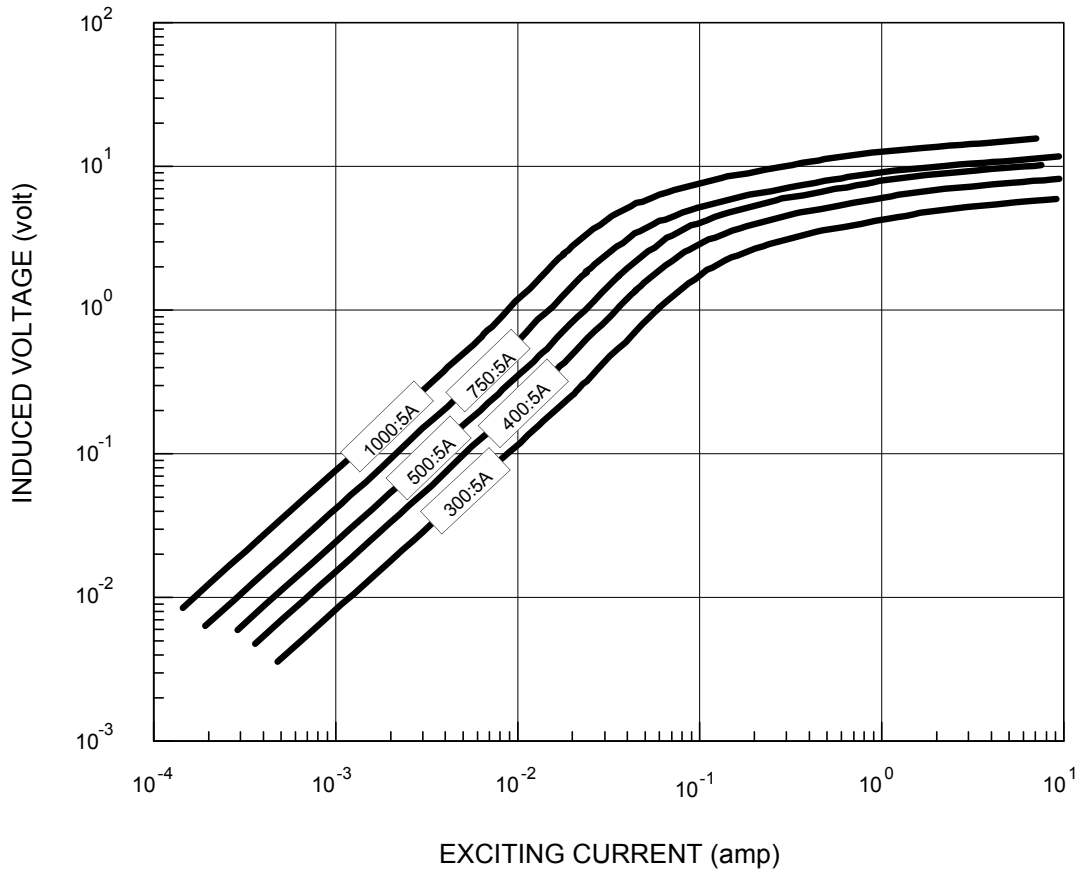

W.I.C.C. PART NUMBER *	RATIO	ACCURACY @ 60HZ, pf = 0.95		NOMINAL WINDING RESISTANCE (ohm)
		± %	BURDEN (VA)	
D-300-00-xxx	300:5A	1.0	5.0	0.08
D-400-00-xxx	400:5A	1.0	7.5	0.10
D-500-00-xxx	500:5A	1.0	12.5	0.13
D-750-00-xxx	750:5A	1.0	15	0.18
D-800-00-xxx	800:5A	1.0	17.5	0.19
D-1000-00-xxx	1000:5A	1.0	20	0.24
D-1200-00-xxx	1200:5A	1.0	20	0.27

* "xxx" describes termination: "T" FOR BRASS STUDS, "Lyyy" FOR LEAD WIRES (Where "yyy" is the lead length in inches. For example, "L24" represents 24 inch long lead wires.)