

W.I.C.C. Ltd
 119 MULLER RD
 PO Box 252
 WASHINGTON IL 61571
 (309)-444-4125
 FAX (309)-444-3313

CURRENT TRANSFORMER MODEL 635

1.10" I.D.

PAGE No

REV 03/22/99

TERMINAL OPTION

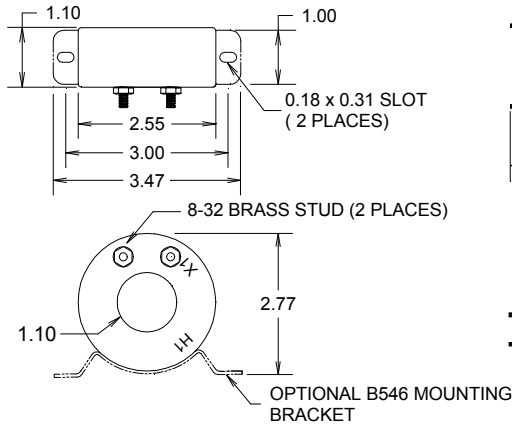

LEAD WIRE OPTION

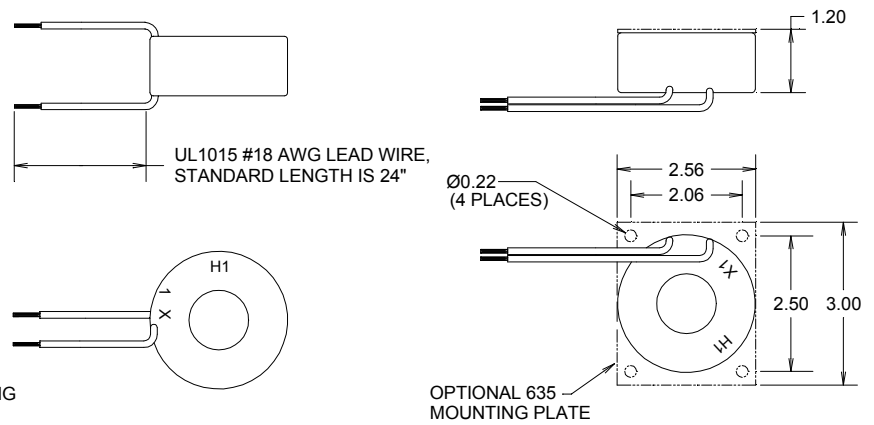

NOTE:
 1) ALL DIMENSIONS IN INCHES
 2) ALL DIMENSIONS REF ONLY

Specifications

- Secondary sources 1 amps AC at rated F.S. primary current
- Nominal operating frequency range is 50-400HZ
- Thermal rating factor is 1.33 @ 30C for all ratios
- Insulation voltage class is 0.6KV BIL 10KV
- For indoor applications only
- Conforms to provisions of IEEE C57.13 and IEC 44-1
- Enclosure is glass-filled nylon, color is black
- Optional plate is XX phenolic, optional bracket is steel

Options, contact Factory for information

- UL and Canadian UL Recognized Component. File E100575
- 2.0, 5.0, and 10 VAC output at F.S. primary amperage. Other non-standard ratings also available.
- 5, 0.2, and 0.1 A output at F.S. primary amperage. Other non-standard ratings also available
- 8-32 Brass Stud Terminals or #18 AWG UL 1015 Lead Wires
- Custom lead wire lengths and types
- Thermal ratings above 1.33 for selected ratios.
- Center tap and custom multi tap winding arrangements

1.10" I.D.

CURRENT TRANSFORMER
MODEL 635

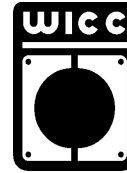

W.I.C.C. Ltd
 119 MULLER RD
 PO Box 252
 WASHINGTON IL 61571
 (309)-444-4125
 FAX (309)-444-3313

PAGE No

REV 03/22/99

TYPICAL EXCITATION CURVE for WICC MODEL 635 at 60HZ

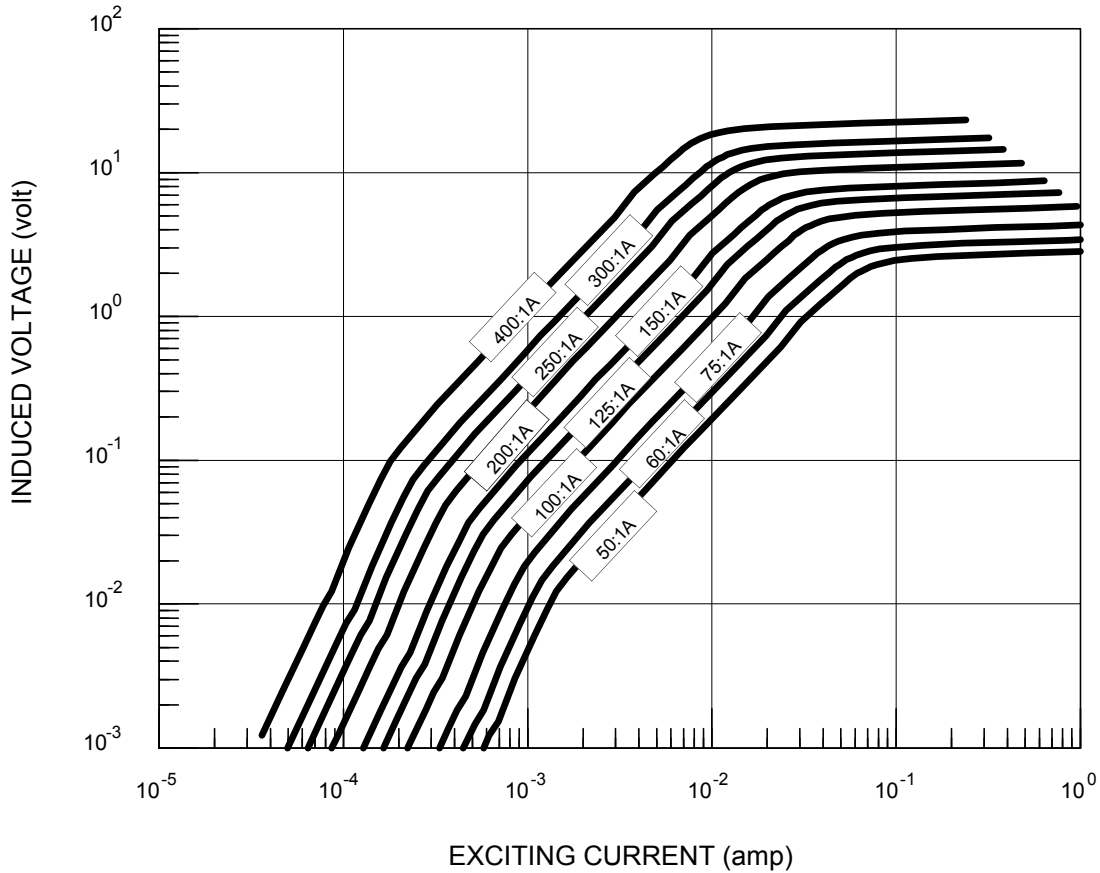

W.I.C.C. PART NUMBER *	RATIO	ACCURACY @ 60HZ, pf = 0.95		NOMINAL WINDING RESISTANCE (ohm)
		± %	BURDEN (VA)	
635-050-01-xxx	50:1A	3.0	1.0	0.05
635-060-01-xxx	60:1A	2.0	1.0	0.06
635-075-01-xxx	75:1A	1.5	1.0	0.15
635-100-01-xxx	100:1A	1.0	1.0	0.31
635-125-01-xxx	125:1A	1.0	2.0	0.38
635-150-01-xxx	150:1A	1.0	3.0	0.57
635-200-01-xxx	200:1A	1.0	5.0	0.95
635-250-01-xxx	250:1A	1.0	7.5	1.20
635-300-01-xxx	300:1A	1.0	10	1.45
635-400-01-xxx	400:1A	1.0	15	2.00

* "xxx" describes termination: "T" FOR BRASS STUDS, "Lyyy" FOR LEAD WIRES (Where "yyy" is the lead length in inches. For example, "L24" represents 24 inch long lead wires.)